

# INSTRUCTION MANUAL FOR

BLUED &  
STAINLESS  
STEEL



CALIBER  
.22 Long Rifle

## **RUGER® MARK II**

AUTOLOADING PISTOLS

STANDARD, TARGET, GOVERNMENT TARGET,  
COMPETITION, AND 22/45 MODELS



**READ THE INSTRUCTIONS AND  
WARNINGS IN THIS MANUAL CAREFULLY  
BEFORE USING THIS FIREARM**

**For Product Service on This Model Please Call:  
(520) 778-6555 (See p. 23)**

**STURM, RUGER & Company, Inc.  
Southport, Connecticut 06490 U.S.A.**

THIS INSTRUCTION MANUAL SHOULD ALWAYS ACCOMPANY THIS FIREARM AND BE  
TRANSFERRED WITH IT UPON CHANGE OF OWNERSHIP, OR WHEN THE FIREARM IS LOANED  
OR PRESENTED TO ANOTHER PERSON

AP & KAP 5/99 R5



# **FIREARMS SAFETY-YOUR RESPONSIBILITY**

## **SAFETY MUST BE THE FIRST AND CONSTANT CONSIDERATION OF EVERY PERSON WHO HANDLES FIREARMS AND AMMUNITION.**

This Instruction Manual is designed to assist you in learning how to use and care for your **RUGER® MARK II** pistol properly. Please contact us if you have any questions about it.

Only when you are certain you fully understand the Manual and can properly carry out its instructions should you practice loading, unloading, etc. with live ammunition. If you have any doubts about your ability to handle or use a particular type of gun safely, you should seek supervised instruction. Such personalized instruction is often available from gun dealers, gun clubs or police departments. If none of these sources can help you, write to the National Rifle Association, 11250 Waples Mill Road, Fairfax, VA 22030-7400. They will assist you.

The person possessing a gun has a full-time job. You cannot guess; you cannot forget. You must know how to use your firearm safely. **Do not use any firearm without having a complete understanding of its particular characteristics and safe use.** Remember: There is no such thing as a foolproof gun.

### **TABLE OF CONTENTS**

	Page
General Information and Mechanical Characteristics .....	3
Operation of the Safety (Illustrations) .....	5
Ammunition .....	7
To Load and Fire (With Magazine) .....	8
To Load and Fire (Without Magazine) .....	10
To Unload .....	11
To Extract and Eject a Chambered Cartridge .....	12
To Clear a Malfunction ("Jam") .....	13
To Minimize Malfunctions ("Jams") .....	13
Basic Disassembly and Reassembly .....	14
Magazine Disassembly .....	19
Care and Cleaning .....	20
Sight Adjustment .....	22
Attaching Ruger Scope Rings .....	22
Service and Parts Policy .....	23
Parts Drawings .....	32, 33, & 34
<b>The Basic Rules of Safe Firearms Handling</b> .....	<b>35</b>
Warranty Information .....	40

"RUGER®" is a registered U.S. trademark.  
 "22/45" is a Sturm, Ruger Trademark.

**WARNINGS OF GREAT IMPORTANCE ARE FOUND ON THE FOLLOWING PAGES:**

Alterations	3	Unloading	10
Manual Safety	5	Malfunctions	13
Lockable Storage Boxes	6	Disassembly	14
Lead Exposure	7	Lubrication	21
Ammunition	7	Storage	21
Firing	9	Parts Purchasers	24
Handling	10		

**OTHER CAUTIONS AND WARNINGS APPEAR THROUGHOUT THE MANUAL.**

**FIREARMS ARE DANGEROUS WEAPONS—  
 READ THE INSTRUCTIONS AND WARNINGS IN THIS  
 MANUAL THOROUGHLY AND CAREFULLY BEFORE USING.**

**WARNING—ALTERATIONS**

This product was designed to function properly in its original condition. Alterations can make it unsafe. Do not alter any part or add or substitute parts or accessories not made by Sturm, Ruger & Co. Inc.

**DO NOT ALTER ANY GUN**

### **GENERAL INFORMATION AND MECHANICAL CHARACTERISTICS**

All **RUGER® MARK II** Standard and Target Models are .22 caliber rimfire, 10-shot, magazine fed, autoloading recoil ('blowback') operated pistols.

The Ruger Government Target Model has a longer, heavyweight barrel and is laser targeted at the factory, just like pistols delivered to the U.S. Government for target shooting and training.

The Ruger Competition Model has a slab-sided, heavyweight barrel with target grips and a scope base supplied with optical sight mounting rings.

The **RUGER® 22/45** has a grip frame assembly made of molded synthetic polymer and a magazine latch button on the left side of the frame.

All **RUGER® MARK II** pistols have the same basic operating mechanism and include the following features with which the gun user should be thoroughly familiar:



# NOMENCLATURE

(All Mark II's other than 22/45)

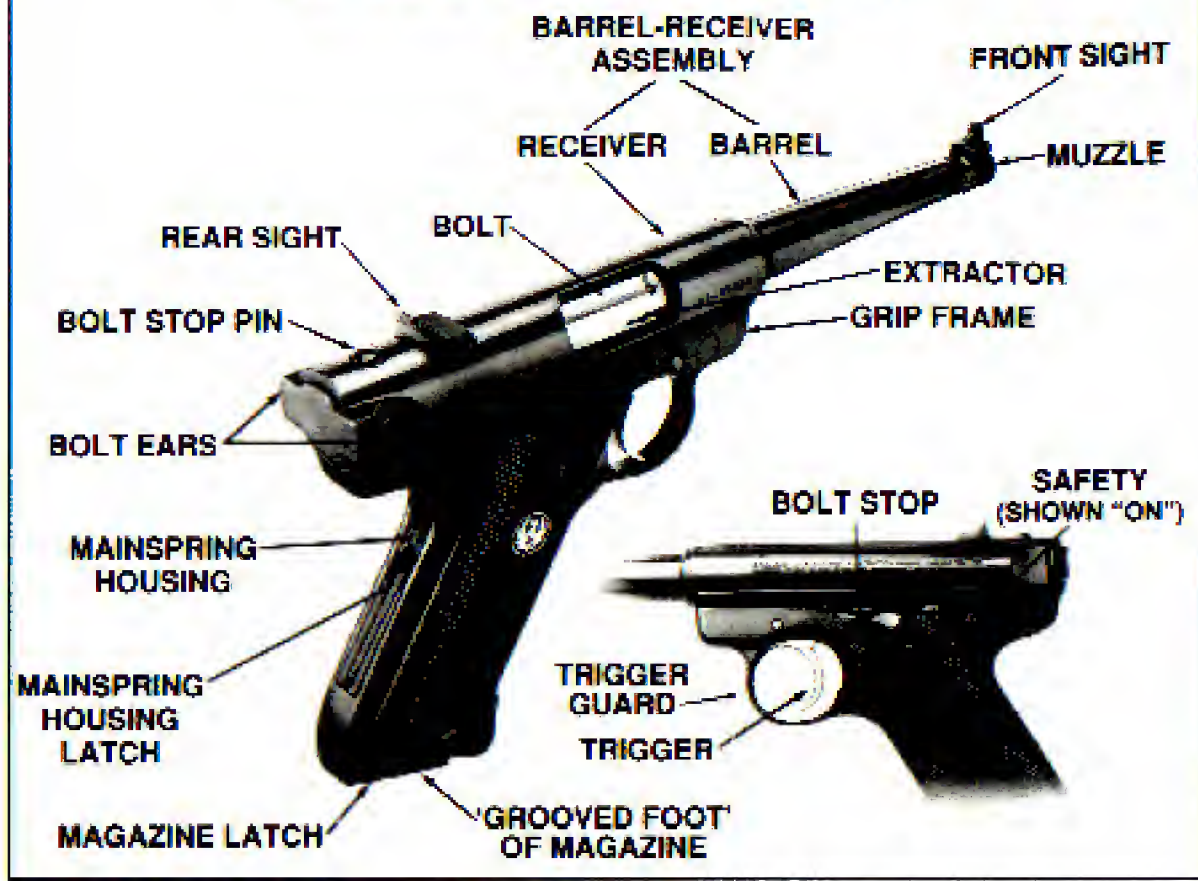

(22/45 shown below)

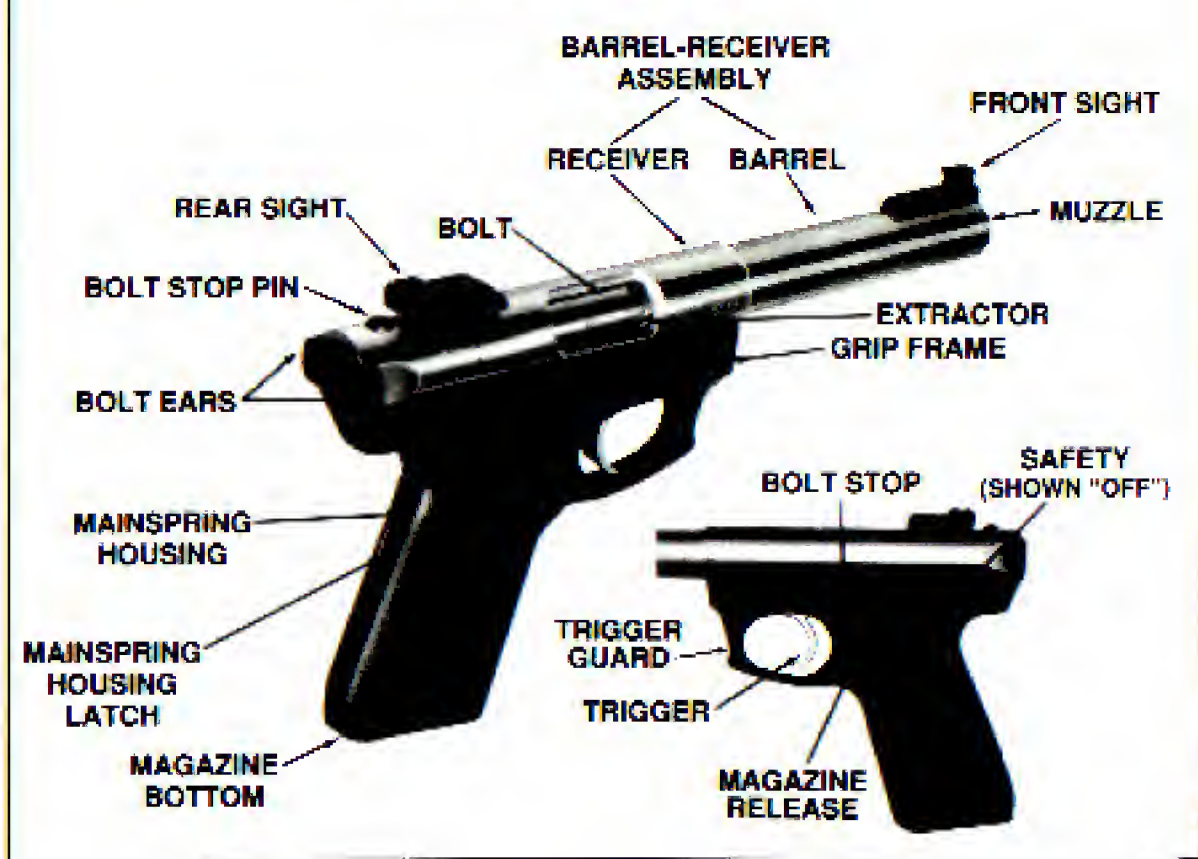

**Safety:** The safety locks the sear when the safety is "on". Because the safety cannot be moved to its "on" (S) position unless the hammer is cocked, the safety therefore serves as a cocking indicator. The bolt can be manually retracted and released when the safety is "on" (S). This feature allows the pistol to be loaded or unloaded when the safety is "on" (S). As shown below and elsewhere in this Manual, the safety should be "on" (the "S" fully showing) at all times except when the gun user is deliberately positioned to fire at a selected target.

## OPERATION OF SAFETY



Figure 1. Safety in the "off" or "fire" (F) position. Safety is all the way down.

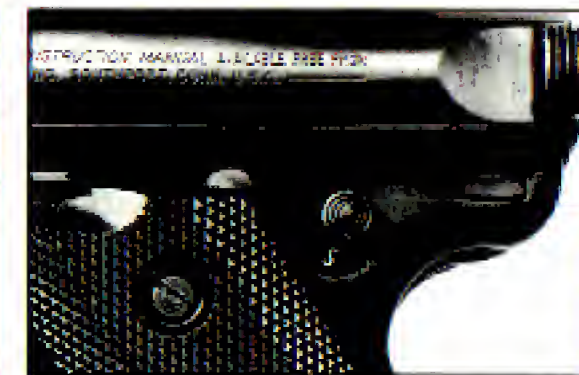



Figure 2. Safety in the "on" or "safe" (S) position. Safety is all the way up.

The Safety is not "on" unless it "clicks" fully up into the "S" position.

**WARNING - MANUAL SAFETY**



Putting the safety between "S" and "F" can result in the pistol firing when the trigger is pulled. Always move the safety fully to its intended position and check it. The safety is not "on" unless it is completely "on". Never depend on a safety mechanism or any other mechanical device to justify careless handling or permitting the pistol to point in an unsafe direction. The only "safe" pistol is one in which the bolt is open, the chamber is empty and there is no magazine in the gun.

**NEVER PUT SAFETY 1/2 ON**

**Bolt Stop:** When the last shot has been fired and the magazine is empty, the bolt stop automatically holds the bolt open. When there is an empty magazine in the pistol and the bolt is retracted manually, the bolt stop will automatically hold the bolt open. If a loaded magazine is inserted in the pistol when the bolt is closed and the bolt is then retracted fully, the bolt stop will not automatically hold open the bolt. The user can actuate the bolt stop mechanism to hold the bolt open at any time by retracting the bolt and pushing up the bolt stop.

The bolt stop can be released when an empty magazine is in the pistol by drawing back slightly on the bolt and depressing the bolt stop thumbpiece. When the bolt is released, it will move forward under pressure from the recoil spring.



The bolt stop is spring-loaded to move downward. Therefore, when there is a loaded magazine in place and the pistol is jarred, the bolt may fly forward and chamber a cartridge. **For this reason and as an essential safety practice, the safety of the pistol should always be in the "on" (S) position except when the user is firing the gun at a selected target.**

**Magazines:** The 10-shot magazine (Part M-10) for the **RUGER® MARK II Standard, Target, Government Target, and Competition Model** pistols is readily identified by the removable plastic bottom decorated with a silver "eagle". The M-10 is the only magazine which should be used in these **RUGER® MARK II** pistols because it is designed to correctly function the bolt stop. The 9-shot, AMC pistol magazine (identified by its brightly plated non-removable bottom) and the AP-10 magazine (with its elongated plastic bottom), which are used in other Ruger pistols should not be used in the above **RUGER® MARK II** pistols.

The **RUGER® 22/45** pistol uses a different 10-shot magazine (part AP-10) which is identified by its removable elongated plastic bottom. It is not interchangeable with the M-10 or AMC magazines described above. See "Magazine Nomenclature," p. 19.

<b>! WARNING - LOCKABLE STORAGE BOXES</b>	
	<p>All Ruger pistols and revolvers are originally sold in a lockable box, with a key-operated padlock. While it can help provide secure storage for your <b>unloaded</b> firearm, any locking device can fail. The ultimate responsibility for secure storage must depend upon its owner and his or her individual circumstances. Always store firearms securely, unloaded, in a secure location, separate from their ammunition.</p> <p>Never leave the keys in the lock. See "Storage Warning", p. 21.</p>
<p><b>DON'T LEAVE KEYS IN THE LOCK</b></p>	<p><b>ALWAYS STORE FIREARMS SECURELY</b></p>

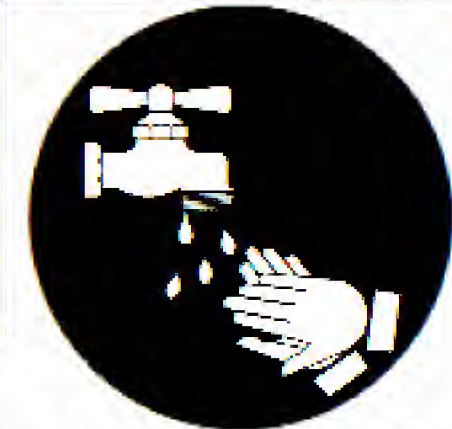
<b>! WARNING - LEAD EXPOSURE</b>	
	<p>Discharging firearms in poorly ventilated areas, cleaning firearms, or handling ammunition may result in exposure to lead and other substances known to the state of California to cause birth defects, reproductive harm, and other serious physical injury. Have adequate ventilation at all times. Wash hands thoroughly after exposure.</p>
<p><b>SHOOTING OR CLEANING GUNS MAY EXPOSE YOU TO LEAD</b></p>	

## AMMUNITION

The **RUGER® MARK II** pistol is chambered only for the .22 caliber Long Rifle cartridge, standard velocity or high velocity, manufactured to U.S. Industry Standards. Do not attempt to load .22 Long, .22 Short, or any other type .22 caliber cartridge into the magazine or in the chamber of the pistol. See MALFUNCTION WARNING, p. 13.

<b>! WARNING - AMMUNITION</b>	
	<p>Death, serious injury, and damage can result from the use of wrong ammunition, bore obstructions, powder overloads, or incorrect cartridge components. .22 cases are very thin and sometimes split when fired. <b>Always</b> wear shooting glasses and hearing protection.</p>
<p><b>IMPROPER AMMUNITION DESTROYS GUNS</b></p>	

**AMMUNITION (CARTRIDGES) NOTICE**

WE SPECIFICALLY DISCLAIM RESPONSIBILITY FOR ANY DAMAGE OR INJURY WHATSOEVER OCCURRING IN CONNECTION WITH, OR AS THE RESULT OF, THE USE IN RUGER PISTOLS OF FAULTY, OR NONSTANDARD, OR "REMANUFACTURED" OR HANDLOADED (RELOADED) AMMUNITION, OR OF CARTRIDGES OTHER THAN THOSE FOR WHICH THE FIREARM WAS ORIGINALLY CHAMBERED.



## TO LOAD AND FIRE (WITH MAGAZINE)

Practice this important aspect of gun handling (with an unloaded pistol) until you can perform each of the steps — described below — with skill and confidence. But before you do anything with the pistol, first read completely through this manual.

1. **Keep the muzzle is pointed in a safe direction.** (See Rule 2, p. 35)
2. Grasp the grooved ears of the bolt and pull the bolt to the rear as far as it will go. (See Figure 3, below) This cocks the hammer and must be done before the safety can be put on. Depress the bolt stop with the thumb of the right hand and release the bolt. **Move the safety fully upward so the "S" shows completely.** (See Figure 2, p. 5)



Figure 3

3. Push the magazine latch and pull the magazine down out of the grip frame by its foot.
4. Put ten (10) or fewer .22 caliber Long Rifle cartridges into the magazine. In loading the magazine make sure that all of the cartridges lie parallel and evenly in the magazine. The follower button on the left side of the magazine is used to lower the follower so the cartridges can be readily inserted.



**CAUTION:** When using the button, have it under control. When loading or handling the magazine, do not pull the button down and then release it suddenly. The rim of the cartridge hitting the magazine lips may set off a sensitive primer and cause the cartridge case to discharge, burst violently, and result in injury.

5. Insert magazine into pistol, taking care that the magazine catch closes fully and thus has the magazine locked in place. Slamming the magazine into the grip frame is not necessary.
6. **Don't touch the trigger.** Pull the bolt to the rear as far as it will go. (See Figure 3, above) Release the bolt so that it will fly forward. (On 22/45 models, the bolt stop must also be depressed to permit the bolt to fly forward). This will place a cartridge into the firing chamber. If the pistol is not to be fired immediately, the safety button should remain "on" — with the "S" showing. (See Figure 2, p. 5)

Once the safety is pushed down so the "F" shows, the pistol will fire a cartridge each time the trigger is pulled, until all of the cartridges in the magazine, and the one in the chamber, have been fired.



7. The pistol is ready for instant use once the safety is disengaged. Firing will automatically reload and recock the pistol. **Note that every time the trigger is pulled, if a cartridge is in the chamber and the safety is "off", the pistol will fire — be careful!**

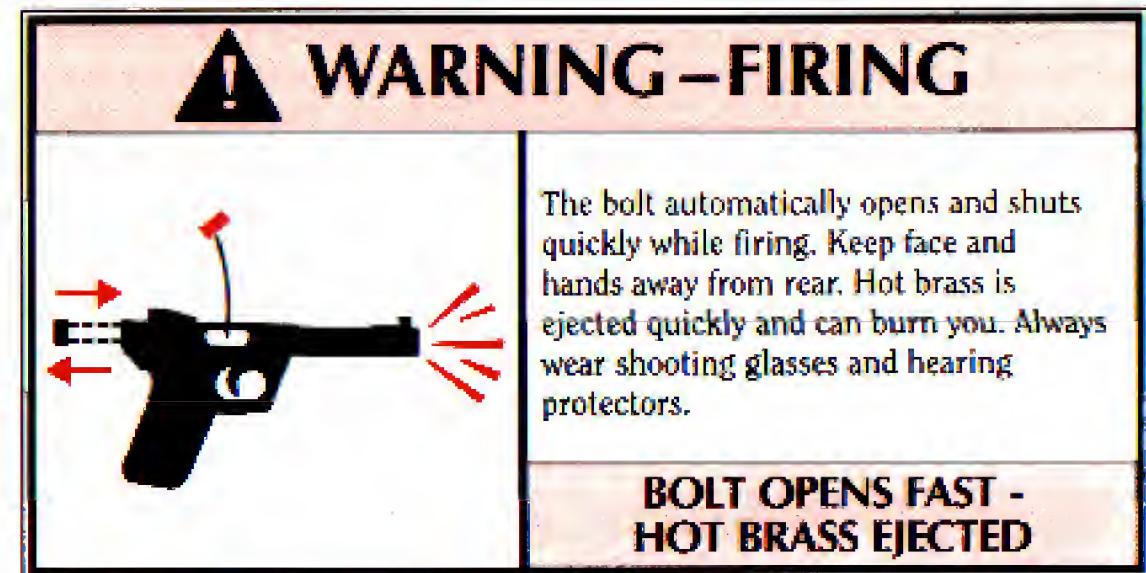

8. **Immediately following the firing of a shot, and if a subsequent shot is not to be fired at once, put the safety in its "safe" position while the pistol is still pointing in a safe direction down range. Never put a loaded pistol down with the safety off!**



<b>⚠ WARNING – HANDLING</b>	
	<p>If dropped or struck with the safety "off", the pistol may fire. Keep chamber empty unless actually firing! Keep safety "on" unless actually firing!</p>
<b>ANY GUN MAY FIRE IF DROPPED</b>	

9. When the last cartridge loaded into the pistol has been fired, the magazine follower presses the slide stop upward to engage the slide automatically holding the action open. **If the slide is shut, the shooter should always assume that there is a cartridge in the chamber!**

**Don't rely on your memory to know if a gun or magazine is loaded. Visually inspect the magazine and the chamber.**

### TO LOAD AND FIRE (WITHOUT MAGAZINE)

In the event that the magazine is missing or for training purposes (where it is desirable that only one cartridge be loaded and fired at a time for safety), the pistol can be fired with the magazine removed. To do so, follow steps 1 and 2, p. 8. Next, grasp the bolt and retract it fully to the rear. Push the bolt stop upward so that the bolt remains to the rear. Insert a single cartridge directly and fully into the chamber. Taking care to keep the pistol pointed in a safe direction, pull the bolt fully to the rear, and depress the bolt stop. This will cause the bolt to move vigorously forward into the firing position. Finally, disengage the safety, and the pistol can be fired by pulling the trigger. Note that the bolt will not automatically remain open if the pistol is fired without the magazine in place.

<b>⚠ WARNING – UNLOADING</b>	
	<p>So that the pistol can be used as a single loader, it will fire whether or not a magazine is in the gun if a cartridge is chambered. Removing magazine does not unload pistol! To unload, <u>first</u> remove magazine, then pull bolt to rear, eject chambered cartridge, and <u>visually inspect chamber</u>. Keep safety "on".</p>
<b>GUN WILL FIRE WITH MAGAZINE OUT</b>	

### TO UNLOAD

**NOTE:** This sequence must be followed exactly as spelled out. Failure to do so can result in the pistol's chamber becoming unintentionally loaded with a cartridge.

1. **The muzzle of the pistol must be pointing in a safe direction at all times, and fingers must be outside the trigger guard.** If the pistol is cocked, **put the safety on** by pushing safety button fully upward.
2. Remove the magazine from the pistol and place it where it will not get damaged or collect dirt. (REMEMBER that even though the magazine has been removed, a cartridge remaining in the chamber can still be fired.)
3. Firmly hold pistol in right hand so that the right thumb is directly underneath the bolt stop. Grasp bolt ears firmly between thumb and forefinger of left hand and snappily retract the bolt to its rearmost position. As the bolt nears the end of its retraction, the chambered cartridge should be extracted and ejected. When the bolt is fully retracted, push upward on bolt stop with thumb, then allow bolt to move forward slowly until it comes to rest against the bolt stop. **Always visually double check the chamber and the interior area of the receiver and the magazine-well to be certain there are no cartridges present.** Gently shake the pistol to dislodge any cartridge which may have been ejected into the magazine-well when the bolt was retracted.

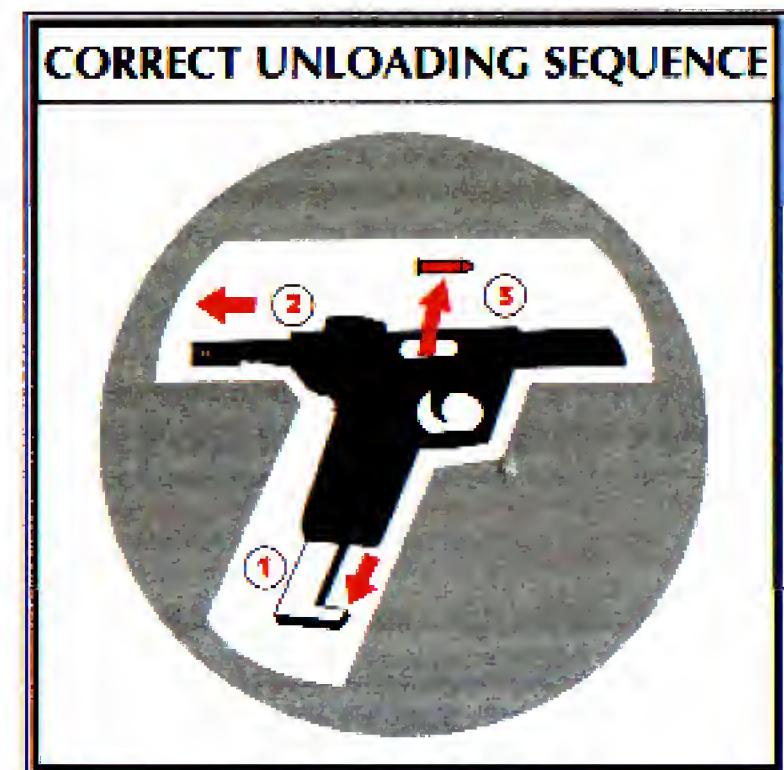



4. If desired, the bolt can be left in the open position, being held there by the bolt stop. If it is desired to close the bolt, again look to be certain the chamber is empty. Assuming that the magazine is not in the pistol and that the safety is "on" (S), retract the bolt to its rearmost position, release it, and the bolt will snap forward. Keep your fingers out of the receiver!
5. With the muzzle pointed in a safe direction, push the safety to the "off" (F) position and pull the trigger to decock the pistol. The pistol can be dry fired as long as the firing pin stop is in place (See NOTE in step 5 on page 16).
6. If the magazine contains cartridges, they can be removed by pressing down slightly on the magazine button (to ease the spring tension) with the thumb, and then sliding the cartridges forward and out of the magazine, one at a time until emptied.
7. Push empty (unloaded) magazine into grip frame until the latch locks it in place.

## TO EXTRACT AND EJECT A CHAMBERED CARTRIDGE

When the pistol is fired, the same gas pressure which drives the bullet forward also acts through the cartridge case to push the bolt to the rear. That action causes extraction and ejection of the fired cartridge case. But, when the bolt is operated by hand, there can be a failure to extract the cartridge from the chamber, or a failure to eject the cartridge clear of the pistol. These failures usually are the result of the bolt not being pulled rearward vigorously, coupled with an accumulation of bullet lubricant in the chamber. From the foregoing it is clear that the gun user must:

1. Always visually check the chamber after opening the bolt to eject a chambered cartridge. If the bolt is not vigorously retracted when being operated by hand, the extracted cartridge can be 'ejected' into the grip frame of the magazine-well.
2. Thoroughly clean the chamber and extractor as often as necessary to prevent the accumulation of grease and dirt.
3. If an empty magazine is in the pistol when the bolt is being hand retracted to extract a cartridge, the cartridge may drop on top of the magazine. Then when the bolt goes forward, the cartridge will be chambered again! Always remove the magazine before clearing the chamber, and visually ensure that no cartridges remain in the gun.

 <b>WARNING – MALFUNCTIONS</b>	
	<p>The .22 Long Rifle rimfire cartridge fires when the firing pin impacts the relatively soft cartridge case rim, and also can be "discharged" before it is chambered if its rim receives a sharp blow. If a cartridge hangs up, jams, or binds when being chambered or when being fed from the magazine into the chamber, do not attempt to force it into the chamber by pushing or striking the bolt. Any jam or feeding problem is a signal to immediately stop using the gun until it can be determined what is wrong. Most failures of a cartridge to feed or to chamber are caused by a damaged magazine, improper gun handling, or defective ammunition. Whatever the cause, rimfire cartridge jams can result in the potentially dangerous situation of a cartridge discharging before it is chambered. If this occurs, the cartridge case will rupture and its fragments will fly out of the gun with sufficient force to cause injury. <b>Always wear shooting glasses and hearing protectors!</b> Keep face away from chamber!</p>
	
<b>CRUSHING RIM CAN BURST AMMO</b>	

## TO CLEAR A MALFUNCTION ("JAM")

1. Be certain the muzzle is pointed in a safe direction and the safety is "on" (S).
2. If possible, first remove the magazine. It may be necessary to manually remove a jammed cartridge which has only partially been stripped from the magazine. If so, use extreme care. Lock the bolt open with the bolt stop before attempting to clear the jam. Drawing the bolt fully to the rear may bring the jammed cartridge along. **Keep your face away from the ejection port during this operation.** When attempting to clear a jam, use only wood "tools" so that a cartridge will not be ignited if you strike a primer and so that the chamber and magazine will not be damaged. A 3/16" wood dowel rod with a point on one end is useful.
3. Visually check to make sure all cartridges have been removed from the pistol. Safely dispose of any cartridges involved in a malfunction incident. Do not use damaged ammunition in any firearm.

## TO MINIMIZE MALFUNCTIONS ("JAMS")

1. If it appears that the gun and magazine are not at fault and that the jam was caused by the type of cartridge being used, then try another type.
2. If changing to another type or brand of cartridges does not at once eliminate malfunctions, then the following steps should be taken:



a. Make certain the gun and the magazine are unloaded and that the safety is "on" (S). Remember, the magazine should be removed first, then check the chamber and be certain it and the magazine-well are clear of cartridges.

b. Thoroughly clean the magazine and bolt mechanism, paying particular attention to removing accumulated grease. Use a bristle brush and solvent to remove grease and fouling from the bolt face, the extractor, the chamber, and the feed ramp. (See the "Care and Cleaning" section of this manual for detailed cleaning instructions.)

c. Check to see that the magazine spring tension is adequate.

d. Check the magazine lips to be certain they are free of nicks and burrs and are not deformed.

e. Remove excess oil and solvent from all cleaned components, load the magazine, and try the firearm again. As always, proceed slowly. **Be certain bystanders are not close and that you are wearing eye and hearing protection and that your face is a safe distance from the pistol so that any discharge resulting from a jammed cartridge will not injure anyone.**

If the above procedures do not result in a smooth and reliably functioning firearm, don't use the gun. The pistol can be returned directly to our Prescott Product Service Department for repair. See the Service and Parts Policy section of this manual for packing and shipping information.

**Another precaution:** when using any firearm chambered for rimfire cartridges, form the habit of examining fired cartridge cases. If they have bulged heads or frequently show splits on any part of the case, the rifle or pistol should be returned to the factory for inspection.

## BASIC DISASSEMBLY AND REASSEMBLY

### ⚠ WARNING – DISASSEMBLY



Always unload a firearm before cleaning, lubrication, disassembly or assembly.

**UNLOAD BEFORE  
CLEANING**

## DISASSEMBLY

1. Remove the magazine. Draw the bolt fully rearward and **visually inspect the chamber to be certain there is no cartridge** in it and then release the bolt. Place the safety in the "off" (F) position. **Point the pistol in a safe direction and pull the trigger**, to be sure hammer has fallen. Hammer must be uncocked before pistol can be disassembled.
2. Insert a blunt, 'pointed' instrument in the oval recess of the mainspring housing (at the back of the grip) and swing the housing latch open like the blade of a pocket knife. (Some users find that a paper clip, looped over the latch, is an ideal 'instrument' for this phase of disassembly.)
3. Swing the entire housing outward on its pivot and pull downward, removing mainspring housing and bolt stop pin. With new pistols it may be necessary to lightly tap (with a plastic hammer) on the top portion of the bolt stop pin—which protrudes above the receiver—while pulling downward on the mainspring housing.
4. Point muzzle up. The bolt will drop out of the receiver or it can readily be removed.
5. With the mainspring housing, bolt stop pin (as an assembly), and bolt removed, a forward blow (with a plastic hammer) on the rear of the receiver will disengage the barrel-receiver assembly from the grip frame. No attempt should be made to remove rivets or staked pins. Further disassembly should be undertaken only by the factory.

## REASSEMBLY

(The procedure is the same for all Ruger MKII pistols)

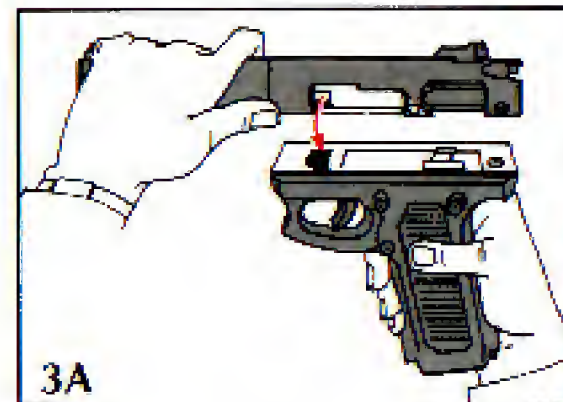

1. **Be certain pistol is free of cartridges!** Safety must be in the "off" (F) position.
2. Place hammer in horizontal (cocked) position. Keep finger off trigger.
3. Place barrel receiver on top of frame so that the square lug engages the square front recess on the underside of the receiver (See Figure 3A).

Push barrel rearward until it stops, with the rear end of receiver slightly over-hanging the rear end of the grip frame (see Figure 3B). If alignment cannot be achieved by hand pressure, strike the muzzle (front) of the barrel with a plastic or wood mallet only, being careful not to damage the muzzle.

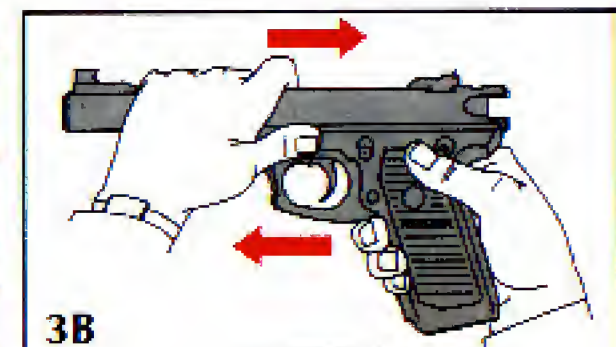



4. Point muzzle up and pull trigger. Gravity will cause the hammer to return to its cocked position if it became dislodged in step 3. (See Figure 4).

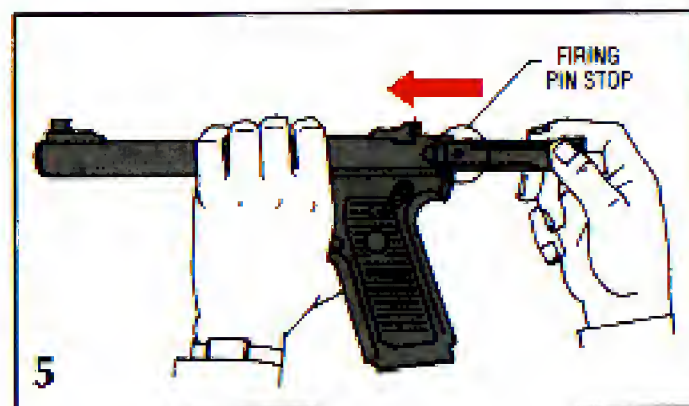

5. Slide bolt (recoil spring upward) fully into receiver. **NOTE:** Before sliding bolt into receiver, **BE CERTAIN** that the firing pin stop (part number A03500, a small pin) is in the bolt. Without this pin, the first time the trigger is pulled on an assembled pistol, the firing pin will fly so far forward so as to irreparably dent the rear end of the chamber of the barrel, making the pistol useless. (See Figure 5).



6. Point muzzle toward ground. Angle the rear of the pistol forward and slightly downward, and pull trigger. Gravity will now cause the hammer to fall to its uncocked position. You can see the hammer fall into this position through the slot in the rear of the grip frame, and when the hammer falls, you will hear a "click". This is essential to all later reassembly steps. Release trigger. (See Figure 6).

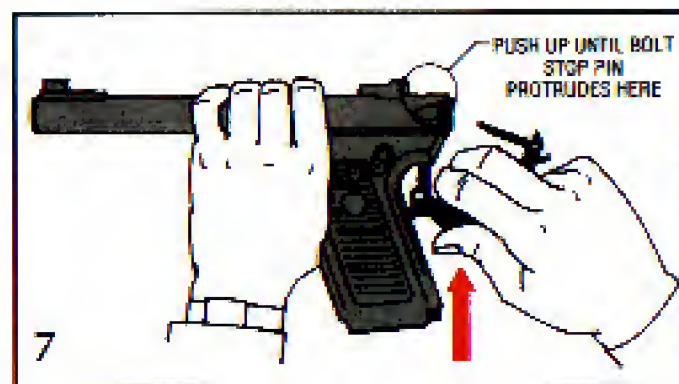

7. Hold the pistol and the mainspring housing bolt stop pin assembly in a horizontal position and press bolt stop pin upward through the holes in the receiver and bolt until the tip of the pin protrudes beyond the top of the receiver. (See Figure 7). Pin must be fully in place to close latch in step 11.

8. (Not applicable to 22/45 models only) Always make sure you can see the hammer strut hanging down inside the housing slot (See Figure 8). Make sure the hammer strut is free to move and not "trapped" behind the crosspin inside the grip frame. If it is, point muzzle forward and pull trigger again. If necessary, gently move the hammer strut over the crosspin with a small screwdriver blade.

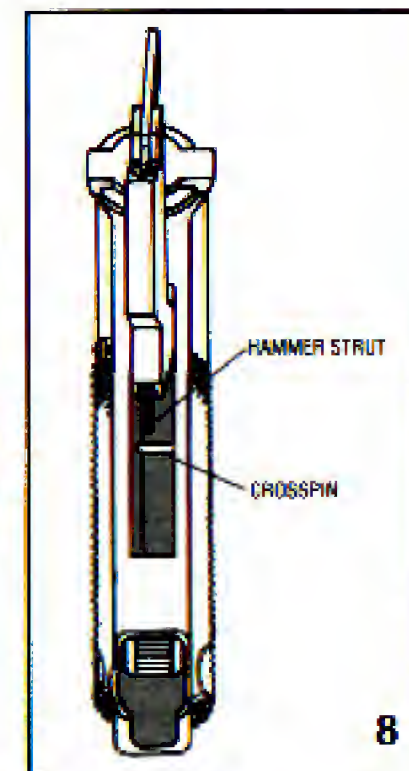

9. Invert the pistol as shown and depress the trigger with your thumb. Hold the pistol as shown in Figure 9.





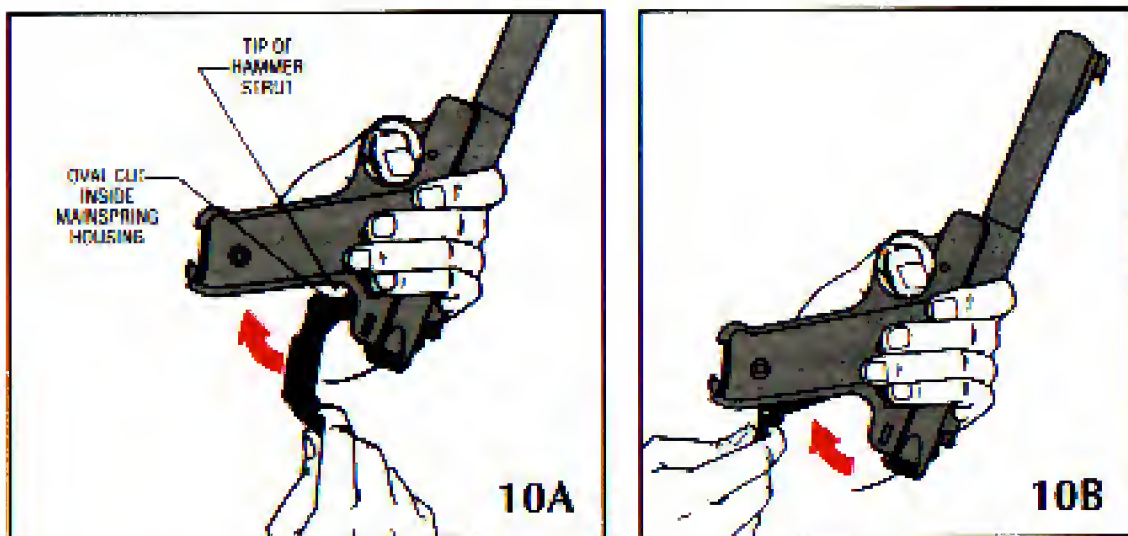

10. Make sure you can see the end of the hammer strut when you lift the housing up (See Figure 10A). The hammer strut should go into the oval-shaped cut inside the mainspring housing. Spring pressure should be felt just before the housing is fully shut if the internal parts are correctly aligned (See Figure 10B).



11. The housing latch can now be snapped shut, completing reassembly. To determine if reassembly is correct, pull bolt back. It should open fully. If not, open latch, remove mainspring housing, and repeat steps 6-10 above.

12. Replace magazine, **point pistol in a safe direction**, and pull trigger to uncock gun. **Guns should not be stored loaded or cocked!**

### **IF YOU HAVE DIFFICULTY REASSEMBLING THE PISTOL, HERE ARE SOME HELPFUL TIPS!**

If the hammer strut does not contact the plunger inside the mainspring housing as it is swung shut, **it will either be impossible to close the housing, or the housing will close but the bolt cannot be fully opened without binding.** Make sure strut is free, hammer is uncocked, and repeat steps 6-11, above.

If the mainspring housing pulls out of the gun when swung in, the barrel/receiver assembly is not fully rearward on the frame. Repeat step 3, above.

Remember that it is essential that the hammer must be in its vertical, uncocked, position as the mainspring housing is swung shut. If the housing is excessively difficult to close, the hammer is probably cocked. Repeat steps 7-12, above.

The foregoing may give the impression that reassembly is difficult, but it is quickly and easily done once properly learned.

## MAGAZINE NOMENCLATURE

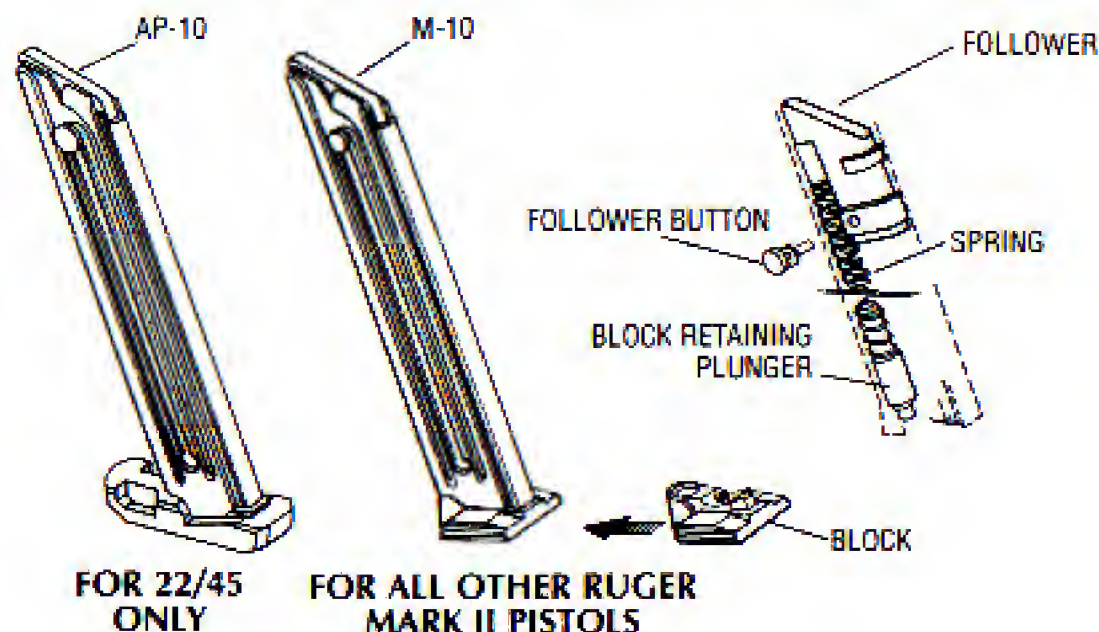

## MAGAZINE DISASSEMBLY

**TO DISASSEMBLE MAGAZINE:** Withdraw magazine from pistol and remove all cartridges (**Check chamber to be certain no cartridge remains in it**). Hold magazine upside down in left hand so that the hole in the Magazine Block is accessible.

1. With right hand, insert drift punch in hole and depress Magazine Block Retaining Plunger approximately 1/4".
2. Slide Magazine Block forward slowly **BEING VERY CAREFUL TO KEEP PLUNGER AND SPRING UNDER CONTROL**. If not contained, these parts will fly out with considerable force. Therefore keep bottom end of magazine pointed away from persons and objects.
3. With the Magazine Block fully removed, the Plunger and Spring should be slowly withdrawn.
4. Now, holding magazine flat in left hand, align the Magazine Follower Button with circular opening near the lower end of magazine body and lift out the Magazine Follower Button.
5. The Magazine Follower can then be removed.

Assemble in reverse order, being careful to contain the Spring and Plunger as the Magazine Bottom is slid and locked into place. After reassembly has been completed, test Magazine Follower to ensure it has free movement.

Always 'ride' the Magazine Follower Button up and down with your thumb. Do not lower Follower Button and then permit it to snap up.



## MAGAZINE DISASSEMBLY

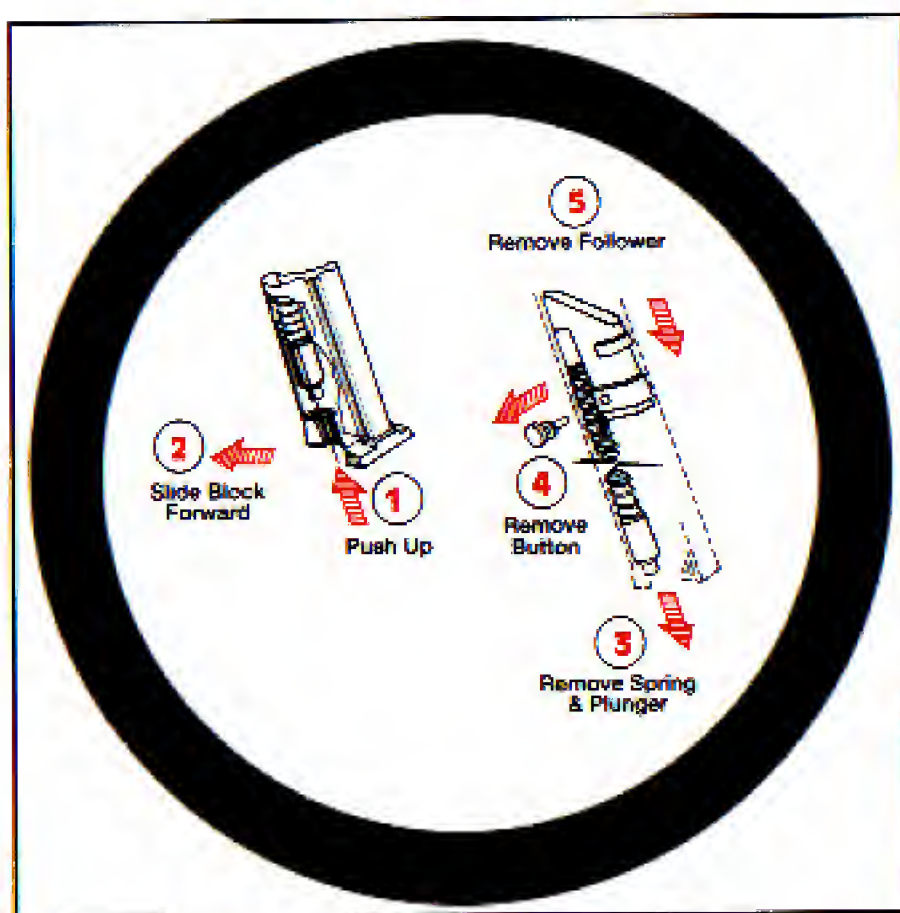

**DAMAGED, NON-STANDARD, OR IMPROPERLY ASSEMBLED MAGAZINES SHOULD NOT BE USED. THEY CAN CAUSE THE PISTOL TO MALFUNCTION.**

## CARE AND CLEANING

### Make Sure Gun is Unloaded!

Before cleaning, be certain the pistol and its magazine contain no cartridges (See "To Unload", p. 11).

At regular intervals, or whenever the pistol has been exposed to sand, dust, extreme humidity, condensation, immersion in water, or other adverse conditions, disassemble, clean, and oil it. Proper periodic maintenance is essential to the reliable functioning of any firearm.

To clean the pistol, proceed as follows:

1. Disassemble (field-strip) the pistol to the extent described on page 15.
2. Using a cleaning rod, run a solvent-wetted patch through the bore several times. Then attach a solvent-wetted bristle brush to the rod and run it back and forth the full length of the bore as many times as necessary to remove grease and dirt from the bore and chamber. Clean bore with dry patches and examine. Bore fouling can contribute to reduced accuracy, and grease accumulation in the chamber can interfere with proper feeding of cartridges from the magazine.

3. Using powder solvent on a clean patch or bristle brush, remove powder residue from all components of the mechanism. After cleaning, run a dry patch through the bore, then follow with a patch that is very lightly oiled. Wipe all surfaces clean with a cloth, then wipe all surfaces with a patch or cloth that has been very lightly oiled.
4. NOTE: Only a light application of oil is needed to provide adequate lubrication of moving parts and to prevent rust. Excess accumulations of oil tend to attract particles of dust and dirt and may congeal in cold weather which can interfere with the safe and reliable function of the pistol.
5. If magazine becomes dirty, it should be disassembled and thoroughly cleaned (See "Magazine Disassembly" section, p. 19).

<b>! WARNING - LUBRICATION</b>	
	<p>Firing a pistol with oil, grease, or any other material even partially obstructing the bore may result in damage to the pistol and serious injury to the shooter and those nearby.</p> <p>Do not spray or apply lubricants directly on ammunition. If the powder of a cartridge is affected by the lubricant, it may not be ignited, but the primer firing may push the bullet into the bore where it may become lodged. Firing a subsequent bullet into the obstructed bore may damage the pistol and cause serious injury or death to the shooter and those nearby. Use lubricants properly. You are responsible for the proper care and maintenance of your firearms.</p>
<b>IMPROPER LUBRICATION DESTROYS GUNS</b>	

6. Before firing remove all oil and grease from the bore. Do not keep the pistol stored in a leather holster or case. Leather attracts moisture, even though the holster or case may appear to be perfectly dry.

<b>! WARNING - STORAGE</b>	
	<p>Never place or store any firearm in such a manner that it may be dislodged. Firearms should always be stored securely and unloaded, away from children and careless adults.</p>
<b>STORE SECURELY &amp; UNLOADED</b>	



## SIGHT ADJUSTMENT

The Standard **RUGER® MARK II** pistol is equipped with a rear sight which is adjustable for windage only. The rear sight can be drifted laterally in its dovetail on the top of the slide by tapping it with a wooden or plastic headed hammer or similar implement. The front sight is fixed. Target models are equipped with adjustable sights. Turning the top (elevation) sight adjustment screw clockwise lowers the impact of the shot. Turning the horizontal (windage) sight adjustment screw clockwise moves the impact of the shot to the left.

### SUGGESTED SIGHT PICTURE

Top of front sight even with top of rear sight blade. Front sight centered in notch of rear sight blade. Target bullseye centered on top of front sight.

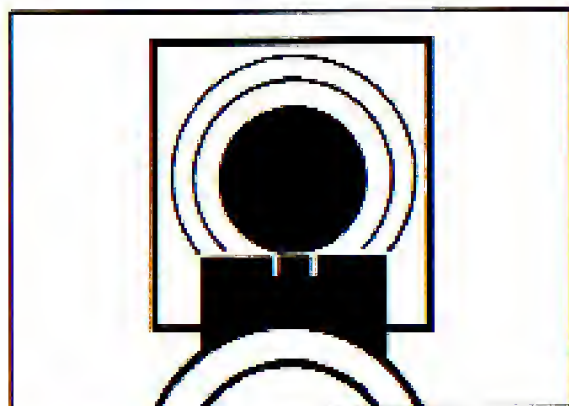

## INSTRUCTIONS FOR ATTACHING THE SCOPE BASE (Competition Model Only)

1. Remove the filler screws from the top of the receiver.
2. Degrease the screw holes in the receiver.
3. Degrease the scope base screws.
4. After the degreased areas are dry, place a drop of red LOCTITE adhesive/sealant or equivalent to the scope base screws.
5. Set the scope base on the receiver with the side notch aligned with the ejection port of the receiver.
6. Install the scope base screws and tighten.
7. Set the assembled pistol aside overnight to allow the adhesive to set up.

## ATTACHING RUGER SCOPE RINGS

On the Mark II COMPETITION TARGET MODEL pistol, the rings fit the removable base (A07000), which is attached as described above. Make sure the scope base screws are tight before attaching the scope ring assemblies!

Iron sights can be used with the scope base mounted on top of the receiver, so removal of the base is not normally necessary. Three "filler" screws (B-83) are provided to fill the scope base screw holes if the user decides to remove the base.

On the underside of each mounting ring assembly there is a locating "tab". By reference to this "tab", the mounting ring can be assembled to the scope so that the tab will fit correctly into the recess on the top of the receiver.

Disassemble one ring and reassemble over the scope body between the turret and the eyepiece so that the clamp nut (D-73) is positioned to the right of the scope.

Install the four top screws. Do not tighten.

Disassemble the other ring and install it on the forward section of the scope tube with the clamp nut positioned to the right of the scope. Install the four top screws. Again, do not tighten.

Assemble the rings to the scope base with the locating "tabs" engaging the recesses in the top surface of the base. Tighten the clamp nuts so that the rings are locked to the semi-circular cuts on the sides of the scope base. Rotate the scope until cross-hairs are aligned properly, and slide scope to desired eye relief.

Then tighten the eight top screws a bit at a time to grip the scope body. Sight in according to the directions with your scope.

## SERVICE AND PARTS POLICY

If you have any questions with regard to the performance of your **RUGER® MARK II** pistol, please call (520-778-6555) or write our Prescott, Arizona Product Service Department, fully describing all circumstances and conditions involved. If you should return your pistol to the factory for repair, or order parts for it, please comply with the following suggestions for prompt service:



**WARNING: BEFORE SHIPPING ANY FIREARM, BE ABSOLUTELY CERTAIN THAT IT AND ITS MAGAZINES ARE UNLOADED. DO NOT SHIP CARTRIDGES WITH A FIREARM.**

## SHIPPING FIREARMS FOR REPAIR

**RUGER® MARK II** pistols returned to the factory for services or repair should be sent to: Sturm Ruger & Co., Inc., Product Service Department, 200 Ruger Road, Prescott, AZ 86301-6181. Telephone: (520) 778-6555.

Guns should be sent prepaid. We will not accept collect shipments.

The Federal Gun Control Act, as well as the laws of most States and localities, do not prohibit an individual (who is not otherwise barred from purchasing or possessing a firearm) from shipping a firearm directly to the manufacturer for repair. However, before you ship your firearm to us, be certain that your State or locality does not have a law or regulation which will prohibit you from receiving it from us after it has been repaired. If such receiving is prohibited, then please have a Federally Licensed firearms dealer ship the gun to us. If it is sent to us by a dealer, it will be returned to him after being repaired. If a handgun (pistol or revolver) is shipped by an individual who does not hold a Federal Firearms License, it must be shipped via U.P.S. Persons who do not hold a Federal Firearms License are prohibited by Federal law from shipping a handgun by Mail. Handguns mailed in violation of the law are impounded by the Post Office.

Please do not include holster, custom grip panels, or custom accessories with a firearm being shipped to the factory for service. **DO NOT SEND GUN BOXES OR LITERATURE THAT YOU CONSIDER TO BE COLLECTOR'S ITEMS - THESE ARE INVARIABLY DAMAGED OR DESTROYED IN SHIPMENT.**

Always insure your shipment.



Enclose a letter which includes your name, address, telephone number, serial number and model of the firearm. Describe in detail the trouble you have experienced with your firearm, or the work you wish to have done. Merely stating that the firearm "needs repair" is inadequate information. State precisely what is wrong. Please enclose copies of any previous correspondence.

Work performed will bear a net minimum labor charge of \$15.00 plus a \$5.00 shipping and handling charge. The charge for metal refinishing the **RUGER® MARK II** pistol is \$35.00 plus a \$5.00 shipping and handling charge. Custom gunsmithing service or nonstandard alterations are NOT AVAILABLE from Ruger Product Service Departments.

<b>⚠ WARNING – PARTS PURCHASERS</b>	
	<p>It is the purchaser's responsibility to be absolutely certain that any parts ordered from the factory are correctly fitted and installed. Firearms are complicated mechanisms and <b>IMPROPER FITTING OF PARTS MAY RESULT IN A DANGEROUS MALFUNCTION, DAMAGE TO THE FIREARM, AND SERIOUS INJURY TO THE SHOOTER AND OTHER PERSONS.</b> The purchaser and installer of parts must accept full responsibility for the correct adjustment and functioning of the pistol after such installation.</p>
<b>PARTS MUST FIT CORRECTLY</b>	

## ORDERING PARTS

Please contact the Arizona Product Service Department for parts availability and current prices. All parts ordered for the **RUGER® MARK II** should be sent to: Sturm, Ruger & Company, Inc., Parts Department, 200 Ruger Road, Prescott, AZ 86301-6181, telephone: (520) 778-6555.

We cannot comply with open account or C.O.D. requests. Payment in the form of a check, money order, Visa or MasterCard must accompany your order. Credit Card orders must include the account number, expiration date and whether it is a Visa or MasterCard account. Minimum parts order is \$1.00 plus a \$3.50 shipping and handling charge. Order parts by Part Name and Part Number and include the entire serial number of the firearm for which the parts are being ordered. The price shown for parts does not include the minimum net labor charge of \$15.00 plus \$5.00 shipping and handling charge if parts are factory fitted. All factory fitted parts are fit on an exchange basis only. We will not return the replaced parts.

\*Parts designated by an asterisk must be factory fitted. These parts are fitted on an exchange basis only. We will not return the replaced parts. We will not return any part that is broken, malfunctioning, badly worn or has been modified. See "Warning – Parts Purchasers" above.

Because it is a serial-numbered component, the **RUGER® MARK II** pistol barrel/receiver assembly is defined as a "firearm" by Federal Law and is not offered for sale separately.



**CAUTION: A gun containing modified, broken, malfunctioning, or badly worn parts should not be fired.**

## RUGER® MARK II PARTS LIST

Design, prices and specifications subject to change without notice.  
**SPECIFY MODEL WHEN ORDERING**  
(See Exploded View on pages 32, 33 & 34)

Part Name	Part No.	Model
* Barrel/Receiver Assembly	-----	Mark II Models
* Barrel/Receiver Assembly	-----	22/45 Models
Bolt Only	A02101	Mark II - Blued Models
Bolt Only	KA02101	Mark II - Stainless Models
Bolt Only	AP02101	22/45 - Blued Models
Bolt Only	KAP02101	22/45 - Stainless Models
Bolt Assembly, Complete, Not Illustrated	A02101-100	Mark II - Blued Models
Bolt Assembly, Complete, Not Illustrated	KA02101-100	Mark II - Stainless Models
Bolt Assembly, Complete, Not Illustrated	AP02101-100	22/45 - Blued Models
Bolt Assembly, Complete, Not Illustrated	KAP02101-100	22/45 - Stainless Models
Bolt Stop Assembly (See Note A on Exploded View)	AN-37	Mark II - Blued Models
Bolt Stop Assembly (See Note A on Exploded View)	KAN-37	Mark II - Stainless Models
Bolt Stop Assembly (See Note B on Exploded View)	AP-37	22/45 - Blued Models
Bolt Stop Assembly (See Note B on Exploded View)	KAP-37	22/45 - Stainless Models
Bolt Stop Pin	A00100	Mark II & 22/45 - Blued Models
Bolt Stop Pin	KA00100	Mark II & 22/45 - Stainless Models
Bolt Stop Pin Pivot	A02602	Mark II & 22/45 - Blued Models
Bolt Stop Pin Pivot	KA02602	Mark II & 22/45 - Stainless Models
Bolt Stop Plunger (See Note A on Exploded View)	A04300	Mark II & 22/45 - Blued Models
Bolt Stop Plunger (See Note A on Exploded View)	KA04300	Mark II & 22/45 - Stainless Models
Bolt Stop Plunger Spg. (See Note A on Exploded View)	A04600	Mark II - Blued Models

\* Contact the Arizona Product Service Department for information regarding Barrel/Receiver Assembly replacement. Be sure to have the complete serial number and model information before calling (520) 778-6555.



<b>Part Name</b>	<b>Part No.</b>	<b>Model</b>
Bolt Stop Plunger Spg. (See <b>Note A</b> on Exploded View)	KA04600	Mark II - Stainless Models
Bolt Stop Plunger Spg. (See <b>Note B</b> on Exploded View) Not Illustrated	AP04600	All 22/45 Models
Bolt Stop Thumbpiece	A04700	Mark II - Blued Models
Bolt Stop Thumbpiece	KA04700	Mark II - Stainless Models
Case Combo - <i>Serial Number Required When Ordering</i>	PGCC-22	Mark II Models except 10" Bull Barrel
Case Combo	PGCC-22/45	All 22/45 Models
Case Combo	PGCC-22/10	Mark II Target (10" Bull Barrel Only)
Case Only - <i>Serial Number Required When Ordering</i>	PGC-RF	Mark II Models except 10" Bull Barrel
Case Only	PGC-RF10	Mark II Target (10" Bull Barrel Only)
* Disconnecter Assembly	KA011	All Mark II & 22/45 Models
Ejector, Not Illustrated	A01600	Mark II & 22/45 - Blued Models
Ejector, Not Illustrated	KA01600	Mark II & 22/45 - Stainless Models
Ejector Rivet, Not Illustrated	A02501	Mark II & 22/45 - Blued Models
Ejector Rivet, Not Illustrated	KA02501	Mark II & 22/45 - Stainless Models
Extractor	KA02200	All Mark II & 22/45 Models
Extractor Plunger	KA02510	All Mark II & 22/45 Models
Extractor Spring	KA20300	All Mark II & 22/45 Models
Firing Pin	A01300	Mark II & 22/45 - Blued Models
Firing Pin	KA01300	Mark II & 22/45 - Stainless Models
Firing Pin Stop	A03500	Mark II & 22/45 - Blued Models
Firing Pin Stop	KA03500	Mark II & 22/45 - Stainless Models
Front Sight, Must Be Drilled For Cross Pin	A01500	Mark II Standard (4" or 6" Barrel)
Front Sight, Must Be Drilled For Cross Pin	A01501	Mark II Target (5 1/4" or 6 7/8" Tapered Barrel)
Front Sight, Must Be Drilled For Cross Pin	AP01501	22/45 (5 1/4" Tapered Barrel)
Front Sight	A03601	Mark II Target (10" Bull Barrel Only)
Front Sight	A03602	Mark II Bull Barrel
Front Sight	A03604	Mark II Competition
Front Sight Pin	A02606	Mark II Standard - Blued Models (4" or 6" Barrel)
Front Sight Pin	KA02606	Mark II Standard - Stainless Models (4" or 6" Barrel)
Front Sight Pin	A02607	Mark II Target - Blued Models (5 1/4" or 6 7/8" Tapered Bbl.)
Front Sight Pin	KA02607	Mark II Target - Stainless Models (5 1/4" or 6 7/8" Tapered Bbl.)
Front Sight Pin	KE02600	22/45 (5 1/4" Tapered Barrel)

<b>Part Name</b>	<b>Part No.</b>	<b>Model</b>
Front Sight Screw	XR07600	All Mark II & 22/45 Models
* Grip Frame, Only	AN-54	Mark II - Blued Models
* Grip Frame, Only	KAN-54	Mark II - Stainless Models
* Grip Frame, Only	AP10100	All 22/45 Models
* Grip Frame, Complete	AN-54-100	Mark II - Blued Models
* Grip Frame, Complete	KAN-54-100	Mark II - Stainless Models
* Grip Frame, Complete	AP10100-100	All 22/45 Models
Grip Panel Screw, Set of 4	A02503	All Mark II Models
Grip Panels, Plastic, Sold in Pairs Only	A00801	All Mark II Models
Grip Panels, Sold in Pairs Only - Checkered Laminated with Left Thumbrest for Right-Handed Shooters Includes Medallion & Screws.	LNPT	All Mark II Models
Grip Panels, Sold in Pairs Only - Checkered Laminated with Right Thumbrest for Left-Handed Shooters Includes Medallion & Screws.	LNPT-LH	All Mark II Models
Grip Panels, Sold in Pairs Only - Smooth Laminated with Left Thumbrest for Right-Handed Shooters Includes Medallion & Screws.	LSPT	All Mark II Models
Grip Panels, Sold in Pairs Only - Smooth Laminated with Right Thumbrest for Left-Handed Shooters Includes Medallion & Screws.	LSPT-LH	All Mark II Models
* Hammer, Only	A01800	Mark II Standard - Blued Models
* Hammer, Only	KA01800	Mark II & 22/45 Standard - Stainless Models
* Hammer, Only	A01801	Mark II Target, Bull Bbl., Competition, Government & 22/45 Bull bbl. - Blued Models
* Hammer, Only	KA01801	Mark II Target, Bull Bbl., Competition, Government & 22/45 Bull Bbl. - Stainless Models
* Hammer Assembly, Complete	A01800-100	Mark II Standard - Blued Models
* Hammer Assembly, Complete	KA01800-100	Mark II & 22/45 Standard - Stainless Models
* Hammer Assembly, Complete	A01801-100	Mark II Target, Bull Bbl., Competition, Government & 22/45 Bull bbl. - Blued Models



<b>Part Name</b>	<b>Part No.</b>	<b>Model</b>
* Hammer Assembly, Complete	KA01801-100	Mark II Target, Bull Bbl., Competition, Government & 22/45 Bull Bbl. - Stainless Models
Hammer Bushing	A02505	Mark II & 22/45 - Blued Models
Hammer Bushing	KA02505	Mark II & 22/45 - Stainless Models
Hammer Pivot	A02605	Mark II - Blued Models
Hammer Pivot	KA02605	Mark II - Stainless Models
Hammer Pivot	AP02605	All 22/45 Models
Hammer Strut	A01000	Mark II & 22/45 - Blued Models
Hammer Strut	KA01000	Mark II & 22/45 - Stainless Models
Hammer Strut Pin	A04900	Mark II & 22/45 - Blued Models
Hammer Strut Pin	KA04900	Mark II & 22/45 - Stainless Models
Lock & Keys - Brass	W11001	All Mark II & 22/45 Models
Lock & Keys - Cast Iron	W11002	All Mark II & 22/45 Models
Magazine, Assembly, Complete, 10-Shot Capacity	M-10	All Mark II Models
Magazine, Assembly, Complete, 10-Shot Capacity	AP-10	All 22/45 Models
Magazine Block Bottom	A01700	All Mark II Models
Magazine Block Bottom	AP01700	All 22/45 Models
Magazine Block Retaining Plunger	A02800	All Mark II & 22/45 Models
Magazine Follower	A02900	All Mark II & 22/45 Models
Magazine Follower Button	A02512	All Mark II & 22/45 Models
Magazine Latch	A00501	Mark II - Blued Models
Magazine Latch	KA00501	Mark II - Stainless Models
Magazine Latch	AP00501	All 22/45 Models
Magazine Latch Pin, 2 Req'd.	A02601	Mark II & 22/45 - Blued Models
Magazine Latch Pin, 2 Req'd.	KA02601	Mark II & 22/45 - Stainless Models
Magazine Latch Spring	A03000	Mark II - Blued Models
Magazine Latch Spring	KA03000	Mark II - Stainless Models
Magazine Latch Spring	KAP03000	All 22/45 Models
Magazine Latch Spring Plunger	KE-61	All 22/45 Models

<b>Part Name</b>	<b>Part No.</b>	<b>Model</b>
Magazine Shell	A04000	All Mark II Models
Magazine Shell	AP04000	All 22/45 Models
Magazine Spring	A03301	All Mark II & 22/45 Models
Mainspring	KA20100	All Mark II & 22/45 Models
Mainspring Detent Ball	KA04100	All Mark II & 22/45 Models
Mainspring Housing, Only	A00900	Mark II - Blued Models
Mainspring Housing, Only	KA00900	Mark II - Stainless Models
Mainspring Housing, Only	AP00901	All 22/45 Models
Mainspring Housing Latch	A00700	Mark II - Blued Models
Mainspring Housing Latch	KA00700	Mark II - Stainless Models
Mainspring Housing Latch	AP00700	All 22/45 Models
Mainspring Housing/Latch Assembly, Not Illustrated	A00901-100	Mark II - Blued Models
Mainspring Housing/Latch Assembly, Not Illustrated	KA00901-100	Mark II - Stainless Models
Mainspring Housing/Latch Assembly, Not Illustrated	AP00901-100	All 22/45 Models
Mainspring Housing Latch Pin	A02602	Mark II & 22/45 - Blued Models
Mainspring Housing Latch Pin	KA02602	Mark II & 22/45 - Stainless Models
Mainspring Plunger	KA02509	All Mark II & 22/45 Models
Medallion	XR05200	All Mark II Models
Rear Sight, Fixed	A06000	Mark II & 22/45 Standard Models
Rear Sight, Adjustable, Complete	A15901-100	Mark II Target, Bull Bbl., Competition, Government & 22/45 Bull Barrel Models
Rear Sight Base	A06100	Mark II Target, Bull Bbl., Competition, Government & 22/45 Bull Barrel Models
Rear Sight Base Set Screw	A06200	Mark II Target, Bull Bbl., Competition, Government & 22/45 Bull Barrel Models
Rear Sight Blade	MR05901	Mark II Target, Bull Bbl., Competition, Government & 22/45 Bull Barrel Models
Rear Sight Blade	SR05904	Mark II Target (10" Bull Barrel Only)
Rear Sight Body, Assembled with Parts	A05900	Mark II Target, Bull Bbl., Competition, Government & 22/45 Bull Barrel Models



Part Name	Part No.	Model
Rear Sight Elevation Screw	MR05902	Mark II Target, Bull Bbl., Competition, Government & 22/45 Bull Barrel Models
Rear Sight Elevation Spring	MR05906	Mark II Target, Bull Bbl., Competition, Government & 22/45 Bull Barrel Models
Rear Sight Pivot Pin	MR05600	Mark II Target, Bull Bbl., Competition, Government & 22/45 Bull Barrel - Blued Models
Rear Sight Pivot Pin	KMR05600	Mark II Target, Bull Bbl., Competition, Government & 22/45 Bull Barrel - Stainless Models
Rear Sight Windage Adjustment Screw	E05903	Mark II Target, Bull Bbl., Competition, Government & 22/45 Bull Barrel Models
Rear Sight Windage Spring	MR05907	Mark II Target, Bull Bbl., Competition, Government & 22/45 Bull Barrel Models
Rebound Spring	A20000	Mark II & 22/45 - Blued Models
Rebound Spring	KA20000	Mark II & 22/45 - Stainless Models
Rebound Spring Support	A03900	Mark II & 22/45 - Blued Models
Rebound Spring Support	KA03900	Mark II & 22/45 - Stainless Models
Recoil Spring Assembly	KA-57	All Mark II & 22/45 Models
* Safety, Assembly, Complete	AN-53	Mark II - Blued Models
* Safety, Assembly, Complete	KAN-53	Mark II - Stainless Models
* Safety, Assembly, Complete	AP-53	All 22/45 Models
Safety Detent Plunger	A02511	Mark II & 22/45 - Blued Models
Safety Detent Plunger	KA02511	Mark II & 22/45 - Stainless Models
Safety Detent Spring, Not Illustrated	A20200	All Mark II Models
Safety Detent Spring	AP20200	All 22/45 Models
Scope Mount Base (3.421")	A07000	Mark II Competition
Scope Mount Base (4.125"), Extended	A07001	Mark II Competition
Scope Mount Base, Filler Screws, 3 Req'd.	B-83	Mark II Competition
Scope Base Screws, 3 Req'd.	B-89	Mark II Competition
Scope Rings, low rings - blued models	S100RL (AZ)	Mark II Competition
Scope Rings, low rings - stainless models	KS100RL (AZ)	Mark II Competition

See **NOTE C**, p. 34

Part Name	Part No.	Model
Scope Rings, medium rings - blued models	S100RM30mm	Mark II Competition
Scope Rings, medium rings - stainless models	KS100RM30mm	Mark II Competition
* Sear	A01901	Mark II & 22/45 - Blued Models
* Sear	KA01901	Mark II & 22/45 - Stainless Models
Sear Pivot Pin	A02601	Mark II - Blued Models
Sear Pivot Pin	KA02601	Mark II - Stainless Models
Sear Pivot Pin	AP02601	All 22/45 Models
Sear Spring	A03100	Mark II - Blued Models
Sear Spring	KA03100	Mark II - Stainless Models
Sear Spring	AP03100	All 22/45 Models
Sear Spring Stop Pin	A02603	Mark II & 22/45 - Blued Models
Sear Spring Stop Pin	KA02603	Mark II & 22/45 - Stainless Models
* Trigger	A01200	Mark II & 22/45 - Blued Models
* Trigger	KA01200	Mark II & 22/45 - Stainless Models
* Trigger with Overtravel Stop	A01201	Mark II - Blued Models
* Trigger with Overtravel Stop	KA01201	Mark II - Stainless Models
Trigger Pivot Pin	A03400	Mark II - Blued Models
Trigger Pivot Pin	KA03400	Mark II - Stainless Models
Trigger Pivot Pin	AP03400	All 22/45 Models
Trigger Pivot Retainer	KA04200	All Mark II Models
Trigger Pivot Retainer	AP04200	All 22/45 Models
* Trigger Pull, Includes the Installation of Hammer, Trigger with Overtravel Stop, Labor and Shipping	-----	Mark II Standard - Blued Models
* Trigger Pull, Includes the Installation of Hammer, Trigger with Overtravel Stop, Labor and Shipping	-----	Mark II & 22/45 Standard - Stainless Models
Trigger Spring	A20400	Mark II & 22/45 - Blued Models
Trigger Spring	KA20400	Mark II & 22/45 - Stainless Models
Trigger Spring Plunger	A02508	Mark II & 22/45 - Blued Models
Trigger Spring Plunger	KA02508	Mark II & 22/45 - Stainless Models
Trigger Stop Screw	KA05800	Mark II Target Models

\*PARTS SO MARKED MUST BE FACTORY FITTED







## RUGER® COMPETITION MODEL COMPONENT PARTS

(All other parts the same as Mark II)

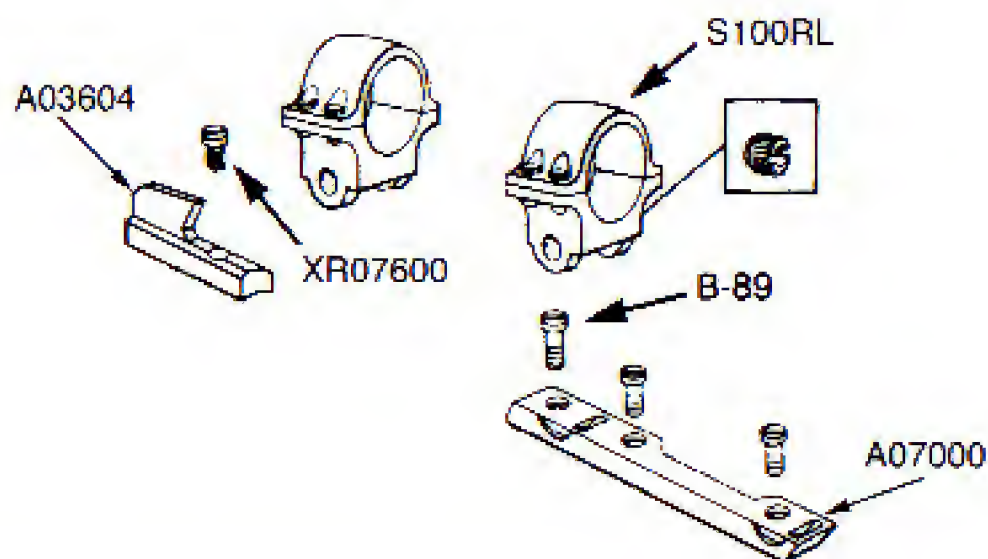

**NOTE C** — Scope mount bases and rings listed will fit all Mark II and 22/45 pistols. Only the Mark II Competition model is drilled and tapped at the factory. All other models must be drilled and tapped by your local gunsmith. Drilling and tapping instructions are available on request.

## THE BASIC RULES OF SAFE FIREARMS HANDLING

We believe that Americans have a right to purchase and use firearms for lawful purposes. The private ownership of firearms in America is traditional, but that ownership imposes the responsibility on the gun owner to use his firearms in a way which will ensure his own safety and that of others. When firearms are used in a safe and responsible manner, they are a great source of pleasure and satisfaction, and represent a fundamental part of our personal liberty.

Firearms do not cause accidents! Firearms accidents are almost always found to have been the result of carelessness or ignorance on the part of the shooter of the basic rules of safe gun handling.

The following rules must be observed by gun users at all times. Safe gun handling is not just desirable, it is absolutely essential to your safety, the safety of others, and the continuation of gun ownership and sport shooting as we know it today.

### 1. LEARN THE MECHANICAL AND HANDLING CHARACTERISTICS OF THE FIREARM YOU ARE USING.



Not all firearms are the same. The method of carrying and handling firearms varies in accordance with the mechanical provisions for avoiding accidental discharge and the various proper procedures for loading and unloading. No person should handle any firearm without first having thoroughly familiarized himself with the particular type of firearm he is using, and with safe gun handling in general.

### 2. ALWAYS KEEP THE MUZZLE POINTED IN A SAFE DIRECTION.



Be sure of the bullet stop behind your target, even when dry-firing. Never let the muzzle of a firearm point at any part of your body or at another person. This is particularly important when loading or unloading a firearm. In the event of an accidental discharge, no injury can occur as long as the muzzle is pointing in a safe direction. A safe direction means a direction which will not permit a discharged bullet to strike a person, or to strike an object from which the bullet may ricochet.



A safe direction must take into account the fact that a bullet may penetrate a wall, ceiling, floor, window, etc., and strike a person or damage property. Make it a habit to know exactly where the muzzle of your gun is pointing whenever you handle it, and be sure that you are always in control of the direction in which the muzzle is pointing, even if you fall or stumble. Keep your finger off the trigger until you are ready to shoot.

### 3. FIREARMS SHOULD BE UNLOADED WHEN NOT IN USE.



Firearms should be loaded only when you are in the field or on the target range or shooting area, ready to shoot. Firearms and ammunition should be securely locked in racks or cabinets when not in use. Ammunition should be safely stored separate from firearms. Store your firearms out of sight of visitors and children. It is the gun owner's responsibility to be certain that children and persons unfamiliar with firearms cannot gain access to firearms, ammunition, or components.

### 4. BE SURE THE BARREL IS CLEAR OF OBSTRUCTIONS BEFORE SHOOTING.

Even a bit of mud, snow or excess lubricating oil or grease in the bore may cause the barrel to bulge, or even burst on firing, and can cause serious injury to the shooter and bystanders. Be sure that you are using ammunition of the proper caliber and loading for the gun you are using. If the report or recoil on firing seems weak, or doesn't seem quite right, **CEASE FIRING IMMEDIATELY**, unload your firearm, and check to be sure that no obstruction has become lodged in the barrel.



### 5. BE SURE OF YOUR TARGET BEFORE YOU SHOOT.

Don't shoot unless you know exactly where your bullet is going to strike. Be sure of the bullet stop behind your target, even when dry-firing with an unloaded gun. If you are in the field hunting, do not fire at a movement or noise. Take the time to be absolutely certain of your target before you pull the trigger.

### 6. WEAR SHOOTING GLASSES AND HEARING PROTECTORS WHEN YOU SHOOT.

All shooters should wear protective shooting glasses and adequate hearing protectors when shooting. Exposure to shooting noise can damage hearing, and adequate eye protection when shooting is essential.



### 7. NEVER CLIMB A TREE OR FENCE WITH A LOADED FIREARM.

Put the firearm down carefully before climbing a fence, and unload it before climbing or descending a tree or jumping over a ditch or other obstruction. Never pull or push a loaded firearm toward yourself or another person. When in doubt, or whenever you are about to do anything awkward, unload your gun!



### 8. DON'T SHOOT AT A HARD SURFACE, OR AT WATER.

Bullets can glance off many surfaces like rocks or the surface of water and travel in unpredictable directions with considerable velocity.



### 9. NEVER TRANSPORT A LOADED FIREARM.

Firearms should always be unloaded before being placed in a vehicle. A suitable carrying case or scabbard should be used to carry an unloaded firearm to and from the shooting area.

### 10. AVOID ALCOHOLIC BEVERAGES WHEN SHOOTING.

Don't drink until the day's shooting is over. Handling firearms while under the influence of alcohol in any form, or medications that could affect your judgment or co-ordination, constitutes a criminal disregard for the safety of others.



## A BRIEF ACCOUNT OF AN EXTRAORDINARY ACHIEVEMENT: RUGER FIREARMS

One of the few American firearms manufacturers whose management has remained unchanged since starting in business, Sturm, Ruger & Company, Inc., had its beginning in a small machine shop occupying a rented frame building in Southport, Connecticut. In January, 1949, with an initial investment of only \$50,000 and an idea, William B. Ruger and Alexander M. Sturm started production of a .22 caliber autoloading pistol – a design which was so successful that it became the cornerstone upon which one of the most comprehensive lines of sporting firearms ever made in America was established. After Alex Sturm's death in 1951, William B. Ruger continued to direct the company alone and today, as Chairman of the Board, he is actively involved in the creative engineering of new products and continues to provide the leadership which has made this 50-year-old company a sound and successful enterprise.

Sturm, Ruger & Company, in this relatively short time, has established itself as a leading small arms design organization, developing a unique and broad line of fine quality sporting, military and police firearms to become one of the world's most famous producers of revolvers, pistols, rifles and shotguns. From 1949 thru 1999 Ruger craftsmen have built many millions of firearms.

During its five decades of growth and progress under the leadership of William B. Ruger, the company has developed a business philosophy and implemented policies which represent a constructive influence in the life of modern America. From the beginning, Sturm, Ruger & Company played a positive role in conservation efforts and has supported the interests of shooters through such groups as the National Rifle Association, National Shooting Sports Foundation, and many regional sportsmen's organizations. The company has always endeavored to market its firearms for constructive and recreational purposes, to emphasize the traditional aspects of shooting, to render meaningful public services and to encourage shooters in constructive and responsible participation in the shooting sports.

Today, Sturm, Ruger & Company is particularly mindful of those elements which have contributed to the creation of its success, and extends heartfelt thanks to its many loyal employees and customers.

A current catalog of Ruger firearms is available free upon request to  
Sturm, Ruger & Co., Southport, CT 06490



## **WHY NO WARRANTY CARD HAS BEEN PACKED WITH THIS NEW RUGER FIREARM**

The Magnuson-Moss Act (Public Law 93-637) does not require any seller or manufacturer of a consumer product to give a written warranty. It does provide that if a written warranty is given, it must be designated as "limited" or as "full" and sets minimum standards for a "full" warranty. Sturm, Ruger & Company, Inc. has elected not to provide any written warranty, either "limited" or "full", rather than to attempt to comply with the provisions of the Magnuson-Moss Act and the regulations issued thereunder. There are certain implied warranties under state law with respect to sales of consumer goods. As the extent and interpretation of these implied warranties varies from state to state, you should refer to your state statutes. Sturm, Ruger & Company wishes to assure its customers of its continued interest in providing service to owners of Ruger firearms.



**STURM, RUGER & Company, Inc.**  
**Southport, Connecticut 06490 U.S.A.**  
**<http://www.ruger-firearms.com>**

**A COPY OF THE INSTRUCTION MANUAL FOR ANY RUGER  
FIREARM IS AVAILABLE FROM THE FACTORY FREE ON REQUEST.  
THESE INSTRUCTION MANUALS CONTAIN IMPORTANT  
WARNINGS WHICH MUST BE UNDERSTOOD  
BEFORE USING THESE FIREARMS.**

"RUGER", the Sturm, Ruger logo, "SINGLE-SIX", "BLACKHAWK", "REDFLAWK", "SECURITY-SIX",  
"SPEED-SIX", "SERVICE-SIX", "BEARCAT", "OLD ARMY", "10/22", "MINI-14", "MINI THIRTY",  
"RANCH RIFLE", "M77", "77/22", "CP-100", "SP101", "P-85" and "VAQUERO"  
are registered U.S. trademarks.

**SALE PRICE**  
**\$ 3 00**